

Optimization and control in the chemical processes

Pulotova Mokhira Rakhmatilloevna

Assisent of the Department of Automation and Management of Technological Processes and Production of the Bukhara Branch of the Tashkent Institute of Irrigation and Mechanization of Agriculture Engineers
City Bukhara, Uzbekistan
EMAIL: Pulotova7676@mail.ru

Abstract - Control is a good alternative solution to obtain the desired product yield and still maintain the safety conditions, without changing the system's configuration or replacing the existent components with new ones. A mathematical model of a thermal cracking coil was developed, based on free radical mechanism and some basic assumptions. In order to predict the coil's behavior (temperature, product yields and pressure), a simulator for the dynamic process was used. This paper represents a preliminary dynamic behavior study for implementing advanced process control and optimization.

Key Words: thermal cracking, coking plant, ethylene furnace, advanced control.

1. INTRODUCTION

The highly used thermal cracking furnaces in today's industry are the cracking furnace from the petrochemical domain (cracking of naphtha, ethane, etc.) and the furnace from the coking plant.

The pyrolysis furnaces can be used for any type of raw material; the only condition is the boiling point that must be under 600°C. The furnace represents the centre of the cracking plant and the consumption of energy is also concentrated in this area. The desired products from this reaction are the light olefins, like: ethylene, propylene and butadiene.

Ethylene is industrially obtained through thermal cracking of hydrocarbons. In order to obtain a larger amount of ethylene and decrease the energy and material loss, the process parameters must be held between certain limits according to C.M. Tham as follows:

- Residence time inside the coil, between 0.08 and 0.25 [s] – as short as possible. In order to reduce the residence time, tubes' diameters are reduced; the fabrication materials improved and the burners tend to be much more efficient.

- Dilution steam measured as the ratio S/H_c (steam/hydrocarbon), between 0.3 and 0.6 – high quantity of steam. The dilution steam is introduced in the process to reduce the coke production and to decrease the gas pressure (minimize the undesired secondary reactions).
- Reaction pressure, between 175 and 240 kPa – as low as possible. Coil output pressure is indirectly controlled by the aspiration pressure of the gas compressor, placed downstream.

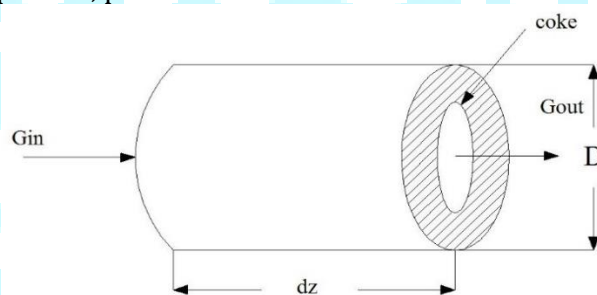

Figure 1. Differential element

- Reaction temperature – at least 900°C – as high as possible. The pyrolysis is an endothermic reaction so a high temperature generates smaller hydrocarbons molecules. A low temperature favors the production of coke and shortens the tubes' "life".

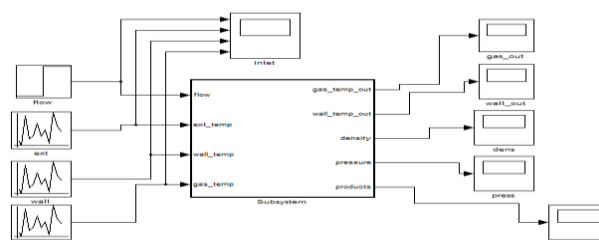

Figure 2. Process simulator

The other process represented by the coking plant is able to upgrade high or low quality vacuum residue, in order to obtain different types of coke and small

petroleum fractions. The main concern is the feedstock composition (the amount of sulphur and metals) when the goal is to obtain high quality coke (needle coke), but when the aim is to produce lighter, more value-added products, the process temperatures and pressure play the most important role. In order to obtain a larger amount of desired products and also decrease the energy and material losses, the process parameters must be held between certain limits.

The free radicals mechanism represents a universal accepted explanation for the hydrocarbons pyrolysis. Once the conversion and the olefin concentration increases, the secondary reactions become more frequent. A small segment of pipe, of infinitesimal volume is represented in Fig. 1.

According to the free radicals mechanism (S. Raseev, 2003), the considered reactions are:

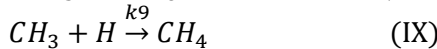
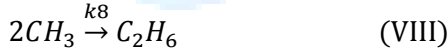
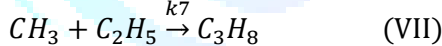
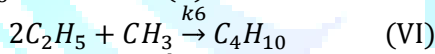
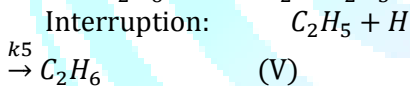
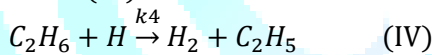
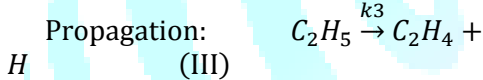
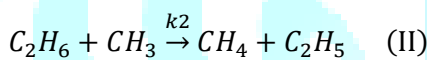
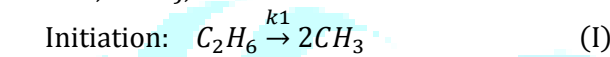

The mathematical description of a one-dimensional plug-flow reactor tube is present below, with the following assumptions: laminar regime, axial dispersion is neglected, ideal gas behavior and inert steam diluents.

Material balance for component j:

$$\frac{dw_j}{dt} = -v \frac{w_j - w_{j,0}}{dz} \times \sum_i r_i \times S(i, j)$$

(1)

where:

$w_j - \left[\frac{kg}{kg} \right]$ - Mass fraction of component j

$w_{j,0} - \left[\frac{kg}{kg} \right]$ - Mass fraction of ethane at the beginning

beginning

$z - [m]$ - Length along coil

$t - [s]$ - Scanning rate

$S(i, j)$ - Stoichiometric constant of component j, in reaction i

$v - [m/s]$ - Fluid velocity

In this

r - reaction rate, evolves with temperature according to an Arrhenius equation:

$$r_i = A_i \times e^{-E_i/R \times T}$$

(2)

where:

$r_i - [kmol/m^3 \cdot s]$ - Reaction rate

And $S(i, j)$ represents the multiplication between the molar concentration of the involved substances.

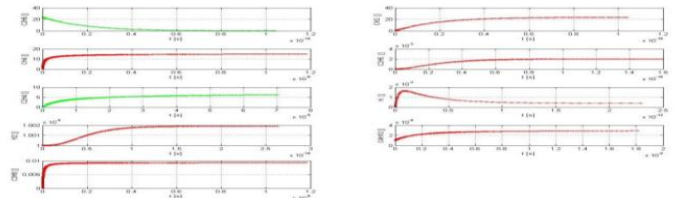

Figure 3. The material evolution

Energy balance:

$$\frac{dT_g}{dt} = \frac{v(T_g - T_{g,0})}{dz} - \frac{[(T_g - T_w) \times A \times k_{tg} + \sum_i r_i H_i + \sigma \times (T_w^4 - T_g^4)]}{\rho \times C_p}$$

(3)

$$\frac{dT_w}{dt} = \frac{A \times k_t \times (T_g - T_w)}{\rho \times C_p}$$

(4)

where:

$C_p - [kcal/kg \cdot K]$ - Process gas specific heat

$H_i - [kcal/kmole]$ - Heat of reaction

$A - [m^2]$ - Transfer tube area

$T_w - [K]$ - Refractory wall temperature

$T_{w,0} - [K]$ - Initial refractory temperature

$T_g - [K]$ - Flue gas temperature

$T_{g,0} - [K]$ - Initial flue gas temperature

$k_{tg} - [W/m \cdot K]$ - Gas thermal conductivity

$k_t - [W/m \cdot K]$ - Tube thermal conductivity

$\sigma - [W/m^4 \cdot K^4]$ - Boltzmann coefficient

referring to radiant energy

Mechanical energy balance:

$$\frac{dP}{dt} = \frac{d\rho}{dt} \times \frac{G_3^2}{\rho^2 \times g} \left(\frac{2f}{D} - 1 \right)$$

(5)

where:

$P - [kgf/m^2]$ - Pressure

$\rho - [kg/m^3]$ - Process gas density

$G_3 - [kg \cdot m/kgf \cdot s^2]$ - Dimensional constant

The result is a time and space variation of all parameters, an isobaric process which depends on the inlet mass flow's variation and considering the inlet gas temperature as a disturbance.

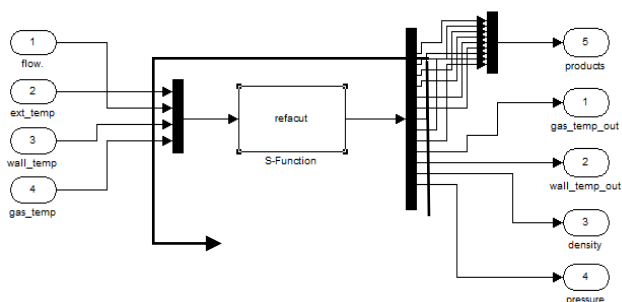

For the entire coil, the implementation was made using ode15s function from Matlab and matrices, solving nine materials balance differential equations: C_2H_6 , CH_3 , CH_4 , C_2H_5 , C_2H_4 , H , H_2 , C_4H_{10} , C_3H_8 , and two energy balance differential equations: gas and wall temperature.

The inlet flow represents 95% ethane. The ethane concentration decreases in time, along with radicals and final products formation (Fig. 3). The radicals' concentrations increase rapidly and afterwards they recombine in final products. In comparison with the other products the concentration of ethylene is high. Due to the fact that the cracking reactions are endothermic, one can observe in Fig. 4, the consumption of energy by decreasing the gas temperature. In time, the gas temperature stabilizes. The wall temperature remains constant in time. The variability is insignificant.

Nowadays the real challenge is to implement the dynamic model in a real time control environment, which is usually not designed for rigorous simulation. The best way to solve differential equations in these cases is to use Euler's Method.

A reliable dynamic model for this type of coil could be used for a future advanced control project, based on the following techniques: feed-forward control, state estimators and predictive model controllers.

The operating objectives should be: to maintain the outlet temperature constant, operate within constraints, minimizing the excess air and fuel consumption. The MPC variables could be the one presented in Table 1, for a small process that needs optimal control, defined constraints and certain optimal set points. These rules could be applied also

in the case of a coking plant when the actual temperature control point is at the heater outlet. The chemical reactions are endothermic and so the coke drum (following the heater) temperature will be lower. If the temperature is too low, the coke will be too soft and the other products' specifications will not be met. If the temperature is too high, the coke will be too hard and difficult to remove (Albers, 1996).

The development of a model for this type of furnace is a theme of present interest because of the petrochemical industry's evolution and of the increased need of optimization.

Table 1. Model predictive control variables

Controlled (CV)	Manipulated (MV)	Constraint (LV)	Disturbances (AV)
Inlet flow	Pass flow	CO	
Combined coil temperature	Fuel demand	Fuel pressure	Heater inlet temperature
	Air demand	Air capacity	
		Firebox temperature	
		Draft pressure	
		Heater temperature	

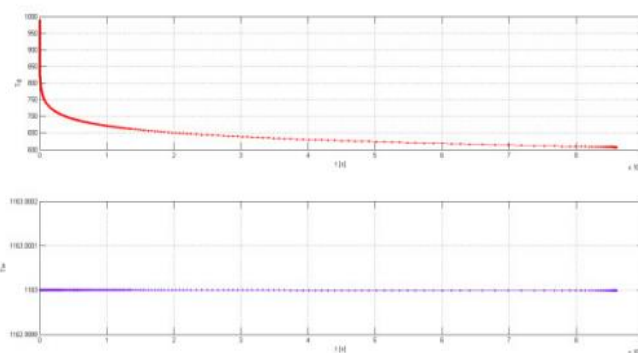

Figure 4. The temperatures evolution

As I have mentioned earlier this paper represents a dynamic regime study that can be followed by the implementation of an advanced process control, like the one presented above: MPC.

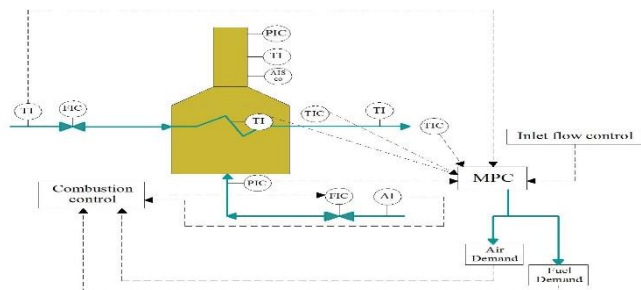

Figure 5. Advanced control system's structure

- [8] 8.Optimization and advanced control for thermal cracking processes. Pulotova Moxira Raxmatilloyna1, Bozorov Prim Raimovich1 Современные материалы, техника и технологии журнал. 2 (10) 2017. 5-10 ст.

2. CONCLUSION

This paper could be the groundwork for the development of a simulator for the entire reactor, with unlimited number of cracking tubes, which could be monitored, and its outlet variables controlled. By using this simulator, a steady state optimization can be tested and even a predictive model can be generated in order to build an MPC preliminary structure, for test purposes and operator trainings. This implemented model can also be the basis when one needs to build an equivalent model in a more real time control environment, much harder to follow.

REFERENCES

- [1] Ахмадова Х.Х. СТАНОВЛЕНИЕ И РАЗВИТИЕ ОТЕЧЕСТВЕННЫХ СИСТЕМ ТЕРМИЧЕСКОГО КРЕКИНГА - Диссертация на соискание ученой степени доктора технических наук. Уфа-2013 г. 457 с.
- [2] A. Niaei, J. Towfighi, et al., 2004, "The combined simulation of heat transfer and pyrolysis reactions in industrial cracking furnace" Applied Thermal Engineering 24 (2004) pp. 2251-2265.
- [3] K. M. Van Geem, R. Zajdlik, et al., 2007, "Dimensional analysis for scaling up and down steam cracking coils" Chemical Engineering Journal 134 (2007) pp. 3-10.
- [4] Program: MATLAB R 2008A, © 1984-2008 The Math Works, Inc. Simulink. Subsystem. Delete Contents, Simulink. Block Diagram. Copy contents to Subsystem, Simulink. Subsystem. Convert to model Reference.
- [5] Програмы: КОМПАС-3D V13, Часть 5. Общие сведения.
- [6] B.G. Houk, et al., 1995, "Model predictive control of a delayed coking unit [DMC]: Development Issues", Chem. Technol. Eur., vol.2, pp. 20-24.
- [7] Application of matlab system for performance of laboratory works on the subject of the theory of automatic control. Pulotova Mohira Rahmatilloeyvna, Namozov Shohrukh Puos o`g`li, Muinov Ulugbek Bahtiyerovich. Вестник науки и образования журнал. 10-2 (64), 2019.